

EQUIVALENT:  
 NSN 1730-01-133-9204  
 214-706-104-101/105  
 214-706-104-003 (OLD STYLE)  
 212-050-200-105/107  
 204-050-200-005/101

NSN 4920-015-492-387  
 NSN 1730-015-492-387

**SPECIFICATIONS:**  
 ATTACH POINTS 2EA. EYE BOLTS  
 16.41" & 17.875" CENTERS  
 OPERATION: HYDRAULIC 8 TON JACK.  
 HI GROSS 10,000 LBS./SIDE  
 TIRE SIZE: 18 X 5.5 105 PSI  
 APPROXIMATE SKID LIFT 6"  
 PICK UP EYE TO TOP OF FRAME 16"  
 WEIGHT EACH SIDE = 95 LBS.  
 SHIPPING DIMENSIONS 19 X 20 X 21  
 FINISH: POWDER COAT ORANGE,  
 CUSTOM COLORS AVAILABLE ON  
 REQUEST.

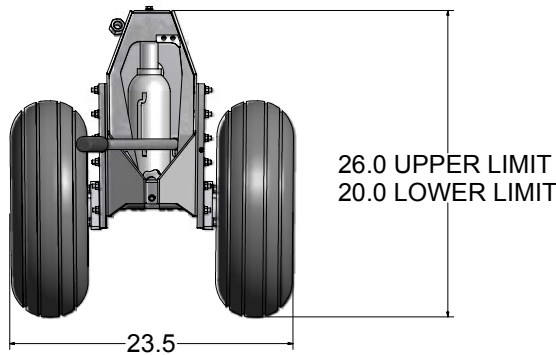
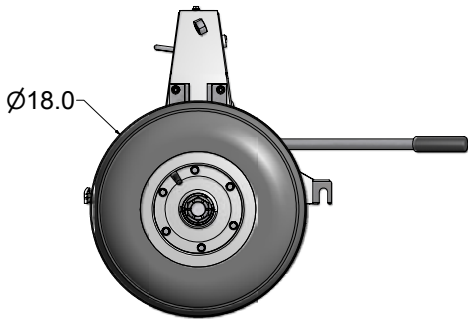

BDW-245B-1801

ITEM	QTY	PART NUMBER	DESCRIPTION
1	1	W-245B-00	WELDED FRAME ASM.
2	2	W-245B-04	AXLE SLIDE
3	2	W-245B-05L	GUIDE LEFT
4	2	W-245B-05R	GUIDE RIGHT
5	4	W-245B-08	WEAR PLATE
6	1	W-245B-09	JACK BASE
7	2	W-245B-11	SPINDLE
8	1	W-245B-13	STOP
9	1	W-245B-15A	BUMP PAD
10	1	W-245B-15B	BUMP PAD
11	1	W-245-22F	JACK
12	2	W-245-25	CASTLE NUT
13	1	W-245B-29	PIN
14	1	W-245B-30	KEEPER PLATE
15	1	CL-8-BLPI-3.00-C	BALL LOCK PIN
16	2	TIRE/WHEEL ASM. (SEE WHEEL ASM. SHEET FOR WHEEL BREAKDOWN)	TIRE/WHEEL ASM.
17	24	5/16-18 X 1 1/2	BOLT
18	24	WASHER 5/16 SAE	WASHER
19	24	5/16-18	LOCK NUT
20	8	3/8	LOCK WASHER
21	8	3/8-24 X 1 1/4	BOLT
22	2	1/8 X 2 1/2	COTTER PIN
23	3	HCLW 1/4 SS	STAINLESS STEEL HIGH COLLAR LOCK WASHER
24	2	1/4-20 X 3/4	ALLEN HEAD BOLT
25	3	10-32 X 3/4 SS BHCS	BUTTON HEAD CAP SCREW
26	1	MCM6391K132	BUSHING
27	1	WASHER FENDER 1/4	FENDER WASHER
28	1	1/4-20 X 1	BOLT
29	6	3/16 X 1/2	ALUMINUM RIVET
30	1	S-264	SPRING
31	4	ZERK 1/4-28	ZERK FITTING
32	1	#10	HI COLLAR LOCK WASHER
33	1	W-245-14-00A	
N.S.	2	W-5.30-8 TB	INNER TUBE
N.S.	2	W-18 X 5.5 TR	TIRE
N.S.	OPT.	608500N SEAL KIT	REPAIR KIT FOR 8 TON NORCO JACK