

CRANK ASSEMBLY

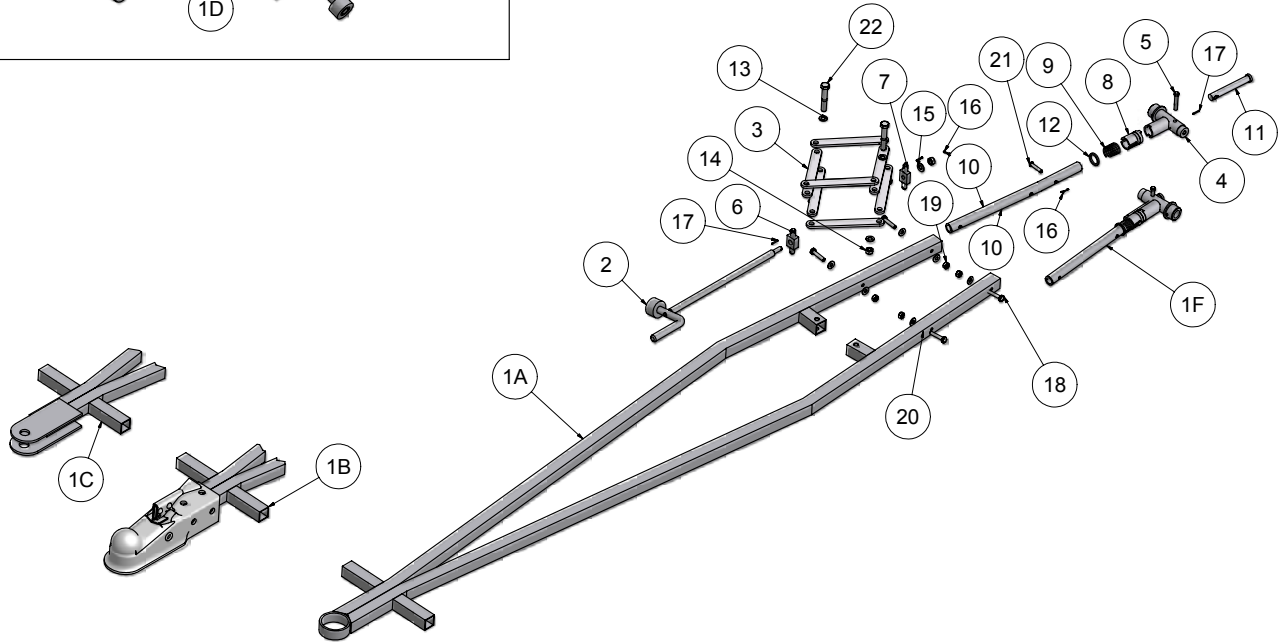
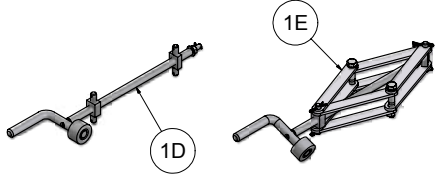

SPECIFICATIONS:  
 MAX. AIRCRAFT GROSS WEIGHT: 4,000 LBS.  
 LENGTH: 6' 2"  
 WEIGHT: 14 LBS. (RING HITCH)  
 15 LBS. (BALL HITCH)

FOR INFORMATION ON OUR ADAPTER APPLICATIONS PLEASE SEE OUR ADAPTER PAGE

ITEM	MODEL: TH-5 (RING)	TH-5B (BALL)	TH-5C (CLEVIS)	QTY	
	PART NUMBER				
1A	T-500	FRAME (RING)		1	
1B	T-500B	FRAME (BALL)		1	
1C	T-500C	FRAME (CLEVIS)		1	
1D	T-345	CRANK ASM.		1	
1E	T-130	CRANK W/STRAPS		1	
1F	T-541	END ASM.		1	
2	T-108	CRANK		1	
3	T-109A	STRAP		8	
4	T-425	END ASM.		2	
5	T-412	PIN		2	
6	T-112	ACME TEE		1	
7	T-113	PLAIN TEE		1	
8	T-420	BARREL		2	
9	T-116	SPRING		2	
10	T-527	END TUBE		2	
11	T-407	PIN		2	
12	T-423	BACKUP WASHER		2	
13	3/8 SAE	WASHER		4	-
14	3/8-24	LOCK NUT		2	-
15	AN960-516	WASHER		2	-
16	1/16 X 1	COTTER PIN		3	-
17	3/32 X 3/4	ROLL PIN		4	-
18	1/4-28 X 1 1/4	BOLT		4	-
19	1/4-28	LOCK NUT		4	-
20	AN960-416L	WASHER		8	-
21	MS20392-3C33	CLEVIS PIN		2	-
22	3/8-24 X 2 1/2	BOLT		2	-